

ELECTRIC PALLET TRUCK

ELUT-20, simple to maintain and afford, the ELUT-20 from Tailift makes it easy to experience the enhanced productivity of a motorized pallet truck. Ergonomically designed and economically priced, it's the ideal user-friendly, budget-friendly solution for a variety of operations and applications.

IDEAL FOR

WHOLESALE
LIGHT DELIVERY
LIGHT DISTRIBUTION

MANUFACTURING
RETAIL
GROCERY

INDUSTRIES

Low to mid-volume companies
Light manufacturing
Beverage
Warehousing
Retail
Distribution



Auto-reversing "belly bump" switch protects against operator accidents while working in tight quarters.

Enhanced operator comfort with a long, ergonomically designed tiller and easily accessible controls for left- and right-handed users.

Easy startup and controlled user access with simple on / off key switch

Emergency stop to disconnect power source to avoid accident when the truck gets out of control (CE option)

Box rail fork construction and special design for fork tips for easy entry and exit of the pallet.

Easy maintenance, simple design, easy access to internal components. . Battery cover, service cover tool-free removal.

Turtle speed setting reduces drive speed for precise positioning or when working in tight quarters

Battery discharge indicator with lift interrupt prevents over-discharging of the battery to protect electrical components.

Standard onboard charger. Faster, more simple and convenient charging.

PRODUCT SPECIFICATIONS

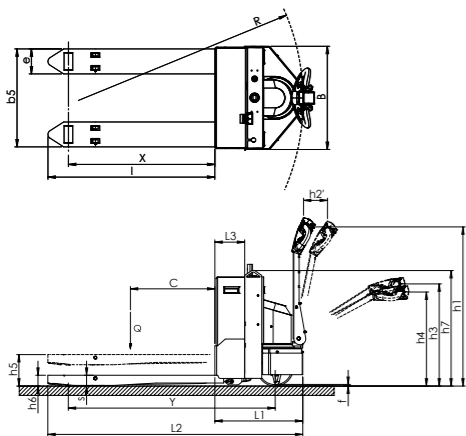

Model	ELUT-20		
Capacity	Q	kg (lb)	2,000 (4,400)
Load center	C	mm (in)	600 (24)
Power source			Electric 24V
Unladen weight (Non Battery)		kg (lb)	345 (759)
Tires, front/rear(X=driven wheel)			2/1 (x=1)
Dimensions of tires (driveside)		mm (in)	Ø 250 (Ø9.9)
Dimensions of tires (loadside)		mm (in)	Ø 85 (Ø 3.3)
Tow bar height (highest)	h1	mm (in)	1115 (43.9)
Tow bar height (second)	h2	mm (in)	150 (5.9)
Tow bar height (third)	h3	mm (in)	715 (28.2)
Tow bar height (lowest)	h4	mm (in)	645 (25.4)
Fork height (highest)	h5	mm (in)	203 (8)
Fork height (lowest)	h6	mm (in)	85 (3.3)
Forks dimensions (LxWxH)	lxexs	mm (in)	1151x172x80 (45.4x6.7x3.1)
Forks width(out to out)	b5	mm (in)	675 (26.6)
Length to face of forks	L2	mm (in)	1756 (69.2)
Length of body	L1	mm (in)	605 (23.8)
Height of body (lowest)	h7	mm (in)	788 (31)
Overall width	B	mm (in)	711 (28)
Battery case width	L3	mm (in)	205 (8.07)
Turning radius (Lifted / Lowered)	R	mm (in)	1556 / 1600 (61.3/63)
From load wheel to cover surface (lifted / lowered)	X	mm (in)	937 / 993 (36.9 / 39.1)
Wheelbase (lifted / lowered)	Y	mm (in)	1364 / 1408 (53.7 / 55.5)
Fork length nominal/actual include forksizes to work in European sized pallets		mm (in)	1220x1150x1165 (48x45.2x45.9)

* This is only for reference and not subject to notice in advance if there is any modification.

Features	ELUT-20	
Travel speed (with load / without load)	km/h(mph/h)	5.4/5.4 (3.4/3.4)
Lift speed (with load / without load)	mm/s (ft/min)	40/52 (7.8/10.2)
Lowering speed (with load / without load)	mm/s (ft/min)	44/47 (8.6/9.2)
Gradeability with load	%	8
Service brake		Hand
Parking lock		Electromagnetic
Battery	AH(max)	12V/55AH/5hr/4pcs
Lift motor	kw	2
Drive motor	kw	1.5
Controller		AC

Accessories ● standard ◎ option

Curtis AC controller	●
AC drive motor	●
Ergonomic control handle	●
Poly drive tire	●
Hour meter / BDI	●
Charger 24V 15A 90-130V 60HZ	●
Charger 24V 15A 180-260V 50-60HZ	◎
Forks 1151x172x80x675mm (45.4 x 6.7 x 3.1 x 26.5")	●
Forks 1151x172x80x550mm (45.4 x 6.7 x 3.1 x 21.6")	◎
Forks 1105x172x80x675mm (43.5 x 6.7 x 3.1 x 26.5")	◎

Accessories ● standard ◎ option

Forks 1105x172x80x550mm (43.5 x 6.7 x 3.1 x 21.6")	◎
Forks 1000x172x80x675mm (39.4 x 6.7 x 3.1 x 26.5")	◎
Forks 1000x172x80x550mm (39.4 x 6.7 x 3.1 x 21.6")	◎
1219mm (48") load backrest	◎
1524mm (60") load backrest	◎
12v / 55ah / 5hr / 4pcs battery& harness	◎
6v / 185ah / 5hr / 4pcs battery & harness	◎
Harness (12V/6V)	◎
Foot protection, 30mm ground clearance	◎
Truck color black grey + orange red	●



No. 5, Zili 1st Road, Nankang Industrial Zone, Nantou city 540, Taiwan R.O.C.
 TEL: +886-49-2263800 FAX: +886-49-2252919
 Website: www.tailift.com E-mail: insales@tailift.com.tw

Notice: As continuous product improvement, the specifications are subject to change without notice and obligation.
 DOC. S/N:DEB078 EDITION: 01