

TRUCK SPECIFICATIONS

9L PLUS II 7.0 TON

PFD70

CHARACTERISTICS			
Capacity	Q	kg	7000
Load center	C	Distance	mm
Power type			Diesel
Operation type		Pedestrian, Stand, Sit	Sit
Tire type	P=Pneumatic, S=Solid	F / R	P / P
DIMENSIONS			
Lift at 2-stage mast	h3	Lift	mm
	h2	Free lift	mm
Load bracket	h8	Height of load bracket	mm
Fork size		Thickness(s)xWidth(e)xLength(l)	mm
Mast tilting angle		Forward(α)/Back(β)	deg
Overall dimensions	L2	Length to face of forks	mm
	B	Total width / dual	mm
	h1	Mast height lowered	mm
	h4	Mast height extended (w/o bracket)	mm
	h4	Mast height extended	mm
	h6	Overhead guard height	mm
Turning radius	R	mm	3280
	X	From center of front axle	mm
	Ast	For load 800x1200/1000x1200	mm
Aisle width			4890/5090
CHASSIS			
Tire size	Wheels (X: Driven)	F / R	4X / 2
Wheelbase	Front		8.25 x 15 x 14PR
	Rear		8.25 x 15 x 14PR
Tread	Center of tires front	mm	1475
	Center of tires rear	mm	1700
Ground clearance	m1	At lowest point	mm
	m2	Center of wheelbase	mm
Service brake	Operation/control		Hydraulic
Parking brake	Operation/control		Hand
POWER			
Battery	Voltage	V	12 x 2
	Capacity	Ah/5hr	112
	Dimension (LxWxH)	mm	504 x 182 x 257
	Weight	kg	26.1
Engine	Manufacturer		KUBOTA
	Model		V3800-TIE5B
	Rated speed	rpm	2400
	Rated Output	kW	83
Transmission	Cylinders no. /displacement	No./L	4 / 3.769
	Fuel consumption	g/kW.h	227 / 2600
Service pressure	Type		Hydraulic
	Stage Fwd./Rev.	no.	2 / 2

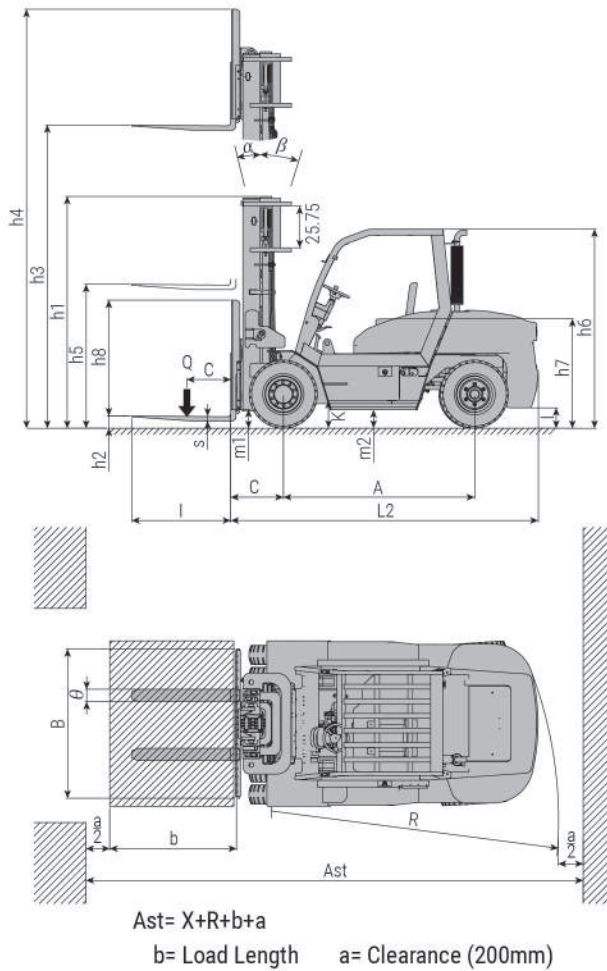

PERFORMANCE			
Speeds	Travel speed	With load	km/h
		Without load	km/h
	Lift speed	With load	mm/s
		Without load	mm/s
Lowering speed	With load	mm/s	
	Without load	mm/s	
Drawbar pull	With load	N	
	Without load	N	
Gradeability	With Load	%	
	Without Load	%	

* This is only for reference and not subject to notice in advance if there is any modification.
 DOC. S/N : DEB105-02

MAST SPECIFICATIONS

Mast Type	Mast Height (Max. Fork Height) in (mm)	Overall Height		Free Lift		Tilt Range		Load Capacity Load Center at 24 in (600mm) With Sideshift Dual Tire lb (kg)	
		Lowered in (mm)	Extended Without STD Backrest in (mm)	With STD Backrest in (mm)	Without STD Backrest in (mm)	With STD Backrest in (mm)	FWD deg		BWD deg
2 Stage	130 (3300)	109.8 (2790)	168.2 (4272)	188.2 (4782)	8.3 (210)	8.3 (210)	6	12	15500 (7000)
	157 (4000)	125.6 (3190)	199.7 (5072)	219.7 (5582)	8.3 (210)	8.3 (210)	6	12	15500 (7000)
2 Stage (FFL)	130 (3300)	104.9 (2665)	181.6 (4612)	201.6 (5122)	63.9 (1623)	43.6 (1109)	6	12	15500 (7000)
	157 (4000)	120.7 (3065)	194.9 (4952)	215.0 (5462)	79.6 (2023)	59.4 (1509)	6	12	15500 (7000)
3 Stage (FFL)	157 (4000)	96.5 (2450)	196.9 (5002)	215.4 (5472)	53.8 (1368)	35.2 (894)	6	6	14620 (6600)
	177 (4500)	103.7 (2635)	216.4 (5498)	234.9 (5968)	61.1 (1553)	42.5 (1079)	6	6	14170 (6400)
	189 (4800)	107.9 (2740)	228.8 (5812)	247.3 (6282)	65.3 (1658)	46.6 (1184)	6	6	13950 (6300)
	236 (6000)	123.6 (3140)	276.0 (7012)	294.5 (7482)	81.0 (2058)	62.3 (1584)	3	6	12180 (5500)

* This is only for reference and not subject to notice in advance if there is any modification.

* With Sideshift & Dual Tire



TAIWAN

Tailift Material Handling Taiwan Co., Ltd.

Head Office

No.5, ZiLi 1st Rd., Nankang Ind. Zone, Nantou City 540, Taiwan R.O.C

TEL: +886-49 226 3800

FAX: +886-49 225 2919

E-Mail: insales@tailift.com.tw

www.tailift.com

Taichung Office

No.269, Section 1, Shein Lin Rd., Taya Dist., Taichung City 428, Taiwan R.O.C

TEL: +886-4 2565 8816

FAX: +886-4 2565 8817

IC COUNTERBALANCE TRUCK

9L PLUS II 7.0 TON



DOC. S/N: DEB105-02



TOYOTA INDUSTRIES GROUP

FEATURES 9L PLUS II 7.0 TON

With unparalleled durability and strength, the PFD70 is undoubtedly one of our most powerful offerings to date. Built to withstand your most demanding job site operations. Featuring the industry's highest-performing engines, powerful hydraulics, and resilient components. Backed by respected engineering and over 50 years of industry experience. Showcasing the latest advancements from Tailift, the user experience is better than ever.

UNMATCHED DURABILITY

HEAVY-DUTY CHASSIS

Our no-bolt heavy-duty chassis provides relentless protection and sturdy longevity. Designed to withstand extreme weight and high temperatures, utilizing the durability of high-carbon German steel.

SUPERIOR GRADEABILITY

Terrain versatility, high-performance acceleration, and powerful incline resistance.



ENGINE

EMISSIONS COMPLIANCE

Satisfying rigid EPA regulations while running cleaner and more efficiently: EPA/CARB Tier 4 Final + EU Stage V

DPF TECHNOLOGY

The advanced technology behind our Diesel Particulate Filters enables automatic regeneration, even at low RPMs, providing cleaner exhaust with a competitive edge.

HIGH PERFORMANCE

Powerful acceleration, full power torque output, and superior resistance with a stable loading idle.

SMOOTH STABILITY

Optimized combustion, with built-in high-pressure common rail and fuel injectors, producing less noise and vibrations.

FUEL EFFICIENCY

High post-processing regeneration efficiency, low regeneration triggering criteria, creating less waste and exhaust.

INNOVATION

The brand-new Kubota V3800-TIE5B Engine features highly-researched innovative emission solutions such as DOC, DPF, and SCR.

EASY MAINTENANCE

The Kubota engine is highly integrated, with a compact and convenient maintenance panel.

CLEAR VISIBILITY

Lowered Lift Cylinders and high-visibility masts provide operators with an unobstructed view.



MAST LOCK SYSTEM (OPTION)

The mast lock system automatically locks all lifting and tilting functions when the operator gets off the seat.

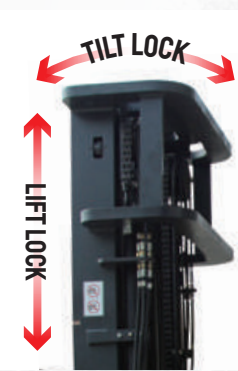

SLOTTED OVERHEAD GUARD

Easily see above, through the heavy-duty safety chassis.



REAR-VIEW

Open rear visibility and wide-angle rear-view mirrors allow operators to see clearly behind.



REAR ASSIST GRIP WITH HORN BUTTON

Rear grip handles are equipped with a horn button for easy access while traveling in reverse.

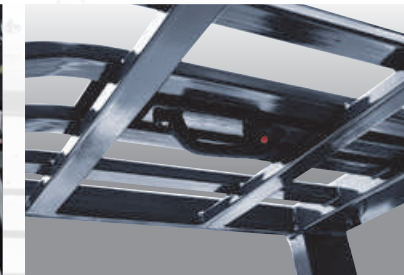

LED FRONT AND REAR LIGHTS

These power-efficient and sleek new LED lights last longer and are brighter than our previous designs!



SUSPENSION SEAT

Our improved seat design can be easily adjusted and prioritizes comfort! The seat easily moves forward and back with an adjustable backrest and retractable seat belt.



AdBlue REPLENISHMENT



MECHANICAL HANDBRAKE

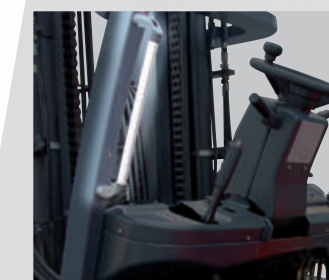
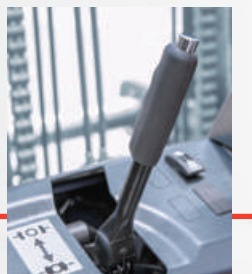

LONG OPERATOR ASSIST GRIPS

Increased length of entry grip handle, for the convenience of forklift operators of any height.

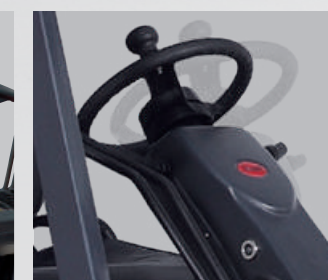

ADJUSTABLE STEERING WHEEL COLUMN

Easily tilted and adjusted to provide an ideal operating position and increased comfort!



INSTRUMENT PANEL

Making performance and functions clear at a glance, while keeping operators informed of all relevant performance indicators.



CAB

Equip with a heater, fan, defrost, and AC option to keep productivity up during any weather.